

Dear customer,  
Thank you for purchasing one of our Durable products. Should you find that any of the contents are damaged and/or a part is missing then please contact your local reseller or dealer. Alternatively, you can contact the Durable Customer Services Department by faxing back the completed form clearly stating which parts are required. Please add also the quantity of each piece required in the box below. Your request will be processed in the shortest delays.

Egregio Cliente,  
La ringraziamo per l'acquisto di un prodotto Durable. Se tuttavia, il suo contenuto dovesse risultare danneggiato e/o mancante di qualche parte, La preghiamo di contattare il Suo fornitore oppure il Servizio Assistenza Durable e inviare per fax questo modulo completato, indicando il numero d'articolo e il numero e la quantità del pezzo che deve essere fornito. Procederemo immediatamente la Sua richiesta.

Sehr geehrter Kunde,  
Vielen Dank für den Kauf dieses Durable-Produktes. Sollte bei diesem Produkt etwas defekt sein oder ein Teil fehlen, kontaktieren Sie bitte Ihren Lieferanten oder den Durable-Kundendienst und faxen Sie dieses Formular vollständig ausgefüllt mit der entsprechenden Teilenummer soviel der benötigten Anzahl. Wir werden Ihre Reklamation unverzüglich bearbeiten.

Cher client,  
Merci d'avoir choisi les produits Durable. Si cependant, une pièce a été endommagée et/ou est manquante, merci de contacter votre revendeur ou le service client Durable en faxant ce document. Il vous suffit de compléter les informations suivantes en notant le code article du meuble, le nombre de pièces à changer dans la ou les cases concernées (à côté des lettres A, B, C...) et en indiquant vos coordonnées. Votre requête sera prise en compte immédiatement.

Geachte klant,  
Bedankt voor de aankoop van dit Durable product. Indien onverhoopt een onderdeel beschadigd is of ontbreekt, dan kunt u dit formulier naar de afdeling Customer Service van Durable toesturen. Vermeldt duidelijk het onderdeelnummer dat moet worden nageleverd. Wij zullen zorgdragen voor een snelle verwerking van uw aanvraag.

Estimado cliente,  
Gracias por comprar productos Durable. Si en algún caso su contenido ha sido dañado y/o alguna parte o componente no aparece en el interior del embalaje por favor contacte con su proveedor o bien envíe un fax al Servicio de Atención al Cliente de Durable, solicitando la referencia del producto que necesita que le suministremos y las unidades requeridas (señalelas en número en el recuadro en blanco). Procesaremos su petición inmediatamente.

<input type="checkbox"/>	A = PA003610006	<input type="checkbox"/>	K = GA7409	<input type="checkbox"/>		<input type="checkbox"/>	
<input type="checkbox"/>	B = PA003730006	<input type="checkbox"/>	L = GA7439	<input type="checkbox"/>		<input type="checkbox"/>	
<input type="checkbox"/>	C = PA00362006	<input type="checkbox"/>	M = PL8XGL7020	<input type="checkbox"/>		<input type="checkbox"/>	
<input type="checkbox"/>	D = PA003620006	<input type="checkbox"/>	N = PL8XGL7019	<input type="checkbox"/>		<input type="checkbox"/>	
<input type="checkbox"/>	E = PA003720006	<input type="checkbox"/>	O = PL12XGL7900	<input type="checkbox"/>		<input type="checkbox"/>	
<input type="checkbox"/>	F = PA003710006	<input type="checkbox"/>	P = PL4X7021	<input type="checkbox"/>		<input type="checkbox"/>	
<input type="checkbox"/>	G = GL7027	<input type="checkbox"/>	Q = PL4XGL7505	<input type="checkbox"/>		<input type="checkbox"/>	
<input type="checkbox"/>	H = GA7080	<input type="checkbox"/>	R = PL4X7522	<input type="checkbox"/>		<input type="checkbox"/>	
<input type="checkbox"/>	I = GL7007	<input type="checkbox"/>	S = PL8XGL7025	<input type="checkbox"/>		<input type="checkbox"/>	
<input type="checkbox"/>	J = GL7950	<input type="checkbox"/>	T = GL7524	<input type="checkbox"/>		<input type="checkbox"/>	

Ship to/An/à envoyer à/A/Aan:  
Company/Firma/Société/Ditta/Fima: \_\_\_\_\_

Att./z.Hd./t.a.v./à l'attention de/attenzione: \_\_\_\_\_

Street/Straße/Rue/Straat/Calle/Strada: \_\_\_\_\_

City/Ort/Ville/Plaats/Residencia/Residenza: \_\_\_\_\_

Country/State/Pays/Land/Pais/Paese: \_\_\_\_\_

Zip/PLZ/Code postal/Postcode/C.A.P./Codigo Postal: \_\_\_\_\_

Phone/Tel/téléphone/No: \_\_\_\_\_ Fax: \_\_\_\_\_

E-mail: \_\_\_\_\_

Durable Customer Service (HQ):  
Tel.: (+49) 2371 662 480

service@durable.de

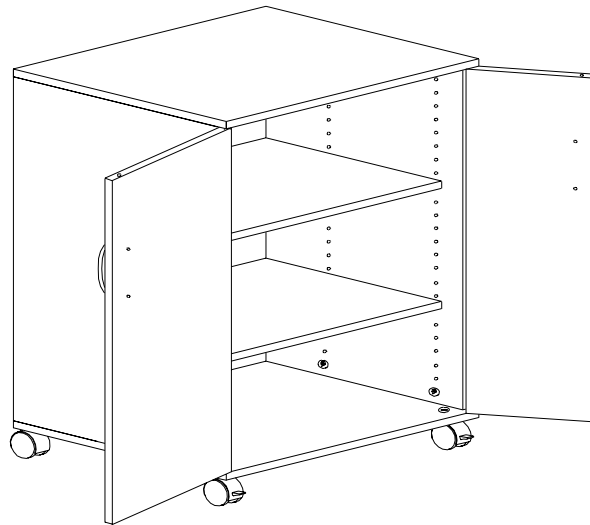

Assembling instructions

Montage Anleitung

Instructions de montage

Montagevoorschrift

Instrucciones de montaje

Instruções de montagem

Istruzioni di montaggio

A1900376

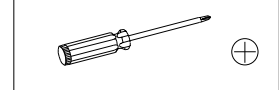
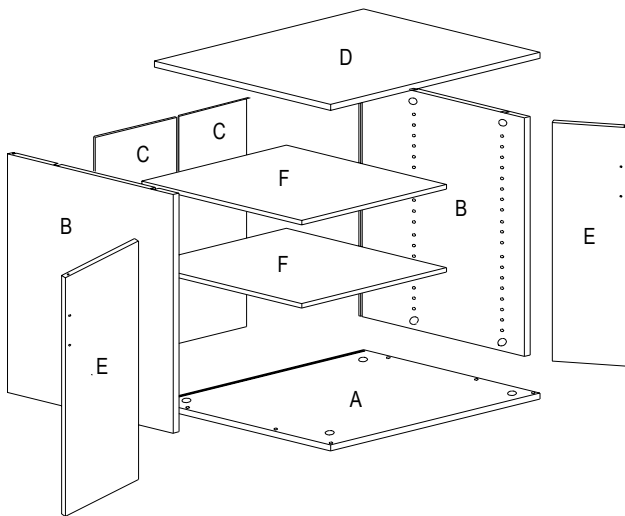

8 x M BAG 8XGL7020

8 x N BAG 8XGL7019

12 x O BAG 12XGL7900

4 x P BAG 4XGL7021

4 x Q BAG 4XGL7505

4 x R BAG 4XGL7522

4 x S BAG 8XGL7025

1 x H

